

**Maintenance-free  
metallic-seat  
non-return valves**



flanged

**PN 6, 16  
DN 15-350**

## Application

- Warm-water heating systems DIN 4751
- Hot-water heating systems DIN 4752
- Heat-transfer installation DIN 4754
- Pressure vessel equipment to TRB 801 nr. 45<sup>1)</sup>
- Boiler installations to TRD 108/110<sup>1)</sup>

<sup>1)</sup> Please contact KSB for limitations imposed by the applicable technical codes.

## Operating data

- Temperature range:
  - 10 up to +300 °C for EN-GJL-250 \*)
  - 10 up to +350 °C for EN-GJS-400-18-LT \*\*)
  - 30 °C for EN-GJS-400-18-LT \*\*) with bolts for low-temperature service
- Pressure range:
  - Straight way pattern up to  $\Delta p = 6$  or 16 bar
  - Angle pattern up to  $\Delta p = 16$  bar

## Materials

Body:

- Straight-way pattern:
  - Cast iron with flake graphite EN-GJL-250 \*)
  - Cast iron with nodular graphite EN-GJS-400-18-LT \*\*)
- Angle pattern:
  - Cast iron with flake graphite EN-GJL-250 \*)
- For further details, see table of materials

## Design

- Straight-way or angle pattern with horizontal seat
- With spring-loaded check cone
- Free from asbestos, CFC, PCB
- Exterior finish: blue similar to RAL 5002

The valves meet the safety requirements of the Pressure Equipment Directive 97/23/EC (PED) of annex I for fluids of the groups 1 and 2.

## Standard variants

- Oil and grease-free design
- Other flange design

## Remarks

- Operating instructions: 0570.8

## On all enquiries/orders please specify

Non-return valve

1. BOA<sup>®</sup>-R according to type series booklet 7117.1
2. PN 6 or 16
3. EN-GJL-250 \*) or EN-GJS-400-18-LT \*\*)
4. Straight-way and angle pattern (angle pattern only EN-GJL-250 \*)
5. DN 15-350 (DN 350 only in EN-GJS-400-18-LT \*\*)
6. Standard variants

\*) previously: GG-25

\*\*\*) previously: GGG-40.3

The valves do not have a potential internal source of ignition and can be used in potentially explosive atmospheres, group II, category 2 (zones 1+21) and category 3 (zones 2+22) according to ATEX 94/9/EC.



## Working pressures

Material	Nominal pressure PN	Body pressure test with water Body <sup>1)</sup>	Seat leakage test with water Seat <sup>2)</sup>	Working pressures in bar at temperatures in °C <sup>3)</sup> to V-DIN 2401 (1.66)				
				- 10 up to +120	200	250	300	350
EN-GJL-250	6	9	7,6	6	5	5	5	-
	16	24	17,6	16	12.8	11.2 <sup>4)</sup>	9.6 <sup>4)</sup>	-
EN-GJS-400-18-LT	16	24	17,6	16	14.7	13.9 <sup>4)</sup>	12.8 <sup>4)</sup>	11.2

<sup>1)</sup> DIN 3230-BQ (ISO 5208)

<sup>2)</sup> DIN 3230-BN/leak rate 1 (ISO 5208/rate A)

<sup>3)</sup> For intermediate temperatures use linear interpolation.

<sup>4)</sup> Note: the connection bolts between valve and pipe flange must also have a guaranteed hot yield strength (e.g. material 5.6 or CK 35 V).

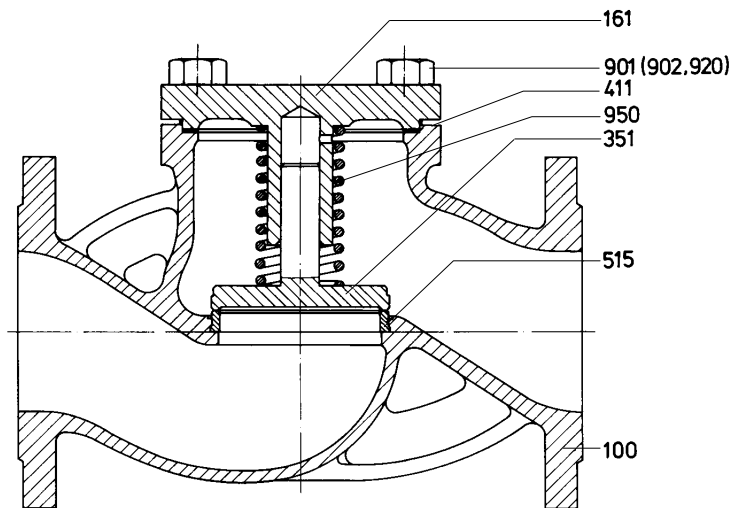

## Materials

Part no.	Name of parts	PN	DN	Material	Material no.
100	Body	6/16	15-300	EN-GJL-250	JL 1040
		16	15-350	EN-GJS-400-18-LT	JS 1025
161	Body cover	6/16	15-300	EN-GJL-250	JL 1040
		16	15-350	EN-GJS-400-18-LT	JS 1025
351	Check cone	6	15-175	X 20 Cr 13	1.4021
		16	15-175		
		6	200	St, seat X 15 CrNi 18 8	1.4301
		16	200-350	Guide pin X 20 Cr 13	1.4021
411	Gasket			CrNiSt-graphite	
515	Seat ring			X 20 Cr 13	1.4021
902	Stud		250-300	CK 35 V for EN-GJL-250	
			15-350	CK 35 V for EN-GJS-400-18-LT	
920	Nut		15-350	C 35	
950	Spring			X 12 CrNi 17 7 (1.4310)	1.4310

## Dimensions

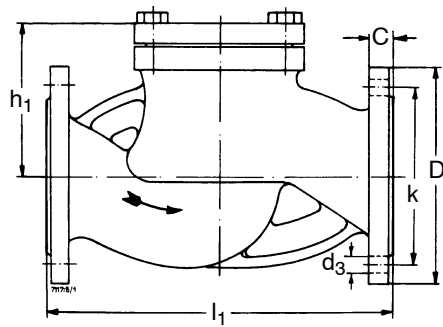

Straight-way pattern

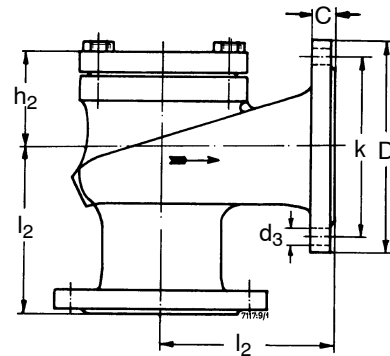

Angle pattern

Dimensions (mm)										Weight (kg) approx.	
PN	DN	l <sub>1</sub>	l <sub>2</sub>	h <sub>1</sub>	h <sub>2</sub>	D	ø k	n x d <sub>3</sub>	C	Straight-way pattern kg	Angle pattern kg
6 <sup>1)</sup> JL1040	15	130	-	50	-	95	55	4 x 11	14	2.3	-
	20	150	-	60	-	105	65	4 x 11	16	3.5	-
	25	160	-	65	-	115	75	4 x 11	16	4.0	-
	32	180	-	85	-	140	90	4 x 14	18	6.9	-
	40	200	-	90	-	150	100	4 x 14	18	8.0	-
	50	230	-	95	-	165	110	4 x 14	20	10.5	-
	65	290	-	120	-	185	130	4 x 14	20	16.8	-
	80	310	-	130	-	200	150	4 x 19	22	22.0	-
	100	350	-	155	-	220	170	4 x 19	24	32.5	-
	125	400	-	175	-	250	200	8 x 19	26	52.0	-
150	480	-	195	-	285	225	8 x 19	26	72.0	-	
200	600	-	245	-	340	280	8 x 19	30	123.0	-	
16 JL1040 JS1025	15	130	90	50	25	95	65	4 x 14	14	2.3	2.2
	20	150	95	60	35	105	75	4 x 14	16	3.5	3.2
	25	160	100	65	35	115	85	4 x 14	16	4.0	4.1
	32	180	105	85	50	140	100	4 x 19	18	6.9	6.9
	40	200	115	90	50	150	110	4 x 19	18	8.0	8.0
	50	230	125	95	60	165	125	4 x 19	20	10.5	10.2
	65	290	145	120	70	185	145	4 x 19	20	16.8	16.1
	80	310	155	130	75	200	160	8 x 19	22	22.0	19.5
	100	350	175	155	95	220	180	8 x 19	24	32.5	30.3
	125	400	200	175	105	250	210	8 x 19	26	52.0	45
	150	480	225	195	110	285	240	8 x 23	26	72.0	64.5
	200	600	275	245	140	340	295	12 x 23	30	123.0	108
	250	730	325	295	150	400	355	12 x 28	32	200.0	170
	300	850	300	335	185	460	410	12 x 28	32	310.0	262
	350 <sup>2)</sup>	980	-	335	-	520	470	16 x 28	36	357.0	-

<sup>1)</sup> Pattern of drilled holes to PN 6 (dimensions k and nxd); however, flanges dimensioned to PN 16 (dimensions D and b). Please take this into account when selecting the flange connecting bolts.

<sup>2)</sup> DN 350 only in EN-GJS-400-18-LT (previously: GGG-40.3) in straight-way pattern on request

## Installation instructions

Observe direction of flow and integral direction arrow.  
For opening, a minimum pressure is required. If this pressure is not attained, the installed closing spring can be removed.  
Valves without a closing spring can only be installed upright in horizontal pipelines.

## Minimum opening pressures (bar)

DN	15-50	65-150	200-350
With spring	0.250	0.200	0.150
Without spring	0.025	0.016	0.022

## Connection dimensions - Standards:

Flanges: DIN EN 1092-2, type of flange 21 - JL1040  
type of flange 21-2 - JS1025

Raised faces: DIN EN 1092-2, type B

Face-to-face dimension:

Straight-way pattern: EN 558-1/1 (previously: DIN 3202/F 1)  
ISO 5752/1

Angle pattern: EN 558-1/8 (previously: DIN 3202/F 32)  
ISO 5752/8

Gasket of  
pure graphite,  
asbestos-free

Closing spring  
of stainless spring  
steel

Check cone of  
stainless steel  
or steel with  
stainless guide  
pin and alloyed  
sealing surface

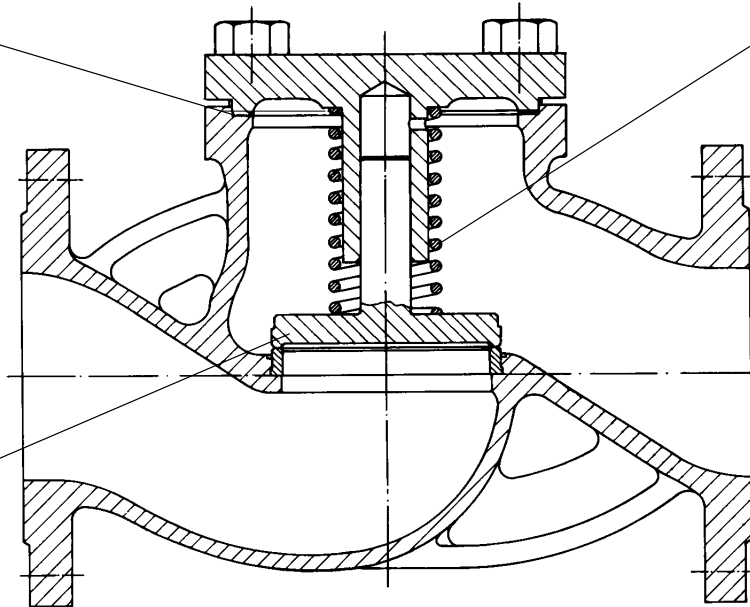

Subject to technical modification without prior notice